

PARTS LIST					
ITEM	QTY	PART NO.	PART DESCRIPTION	UNIT WT.	NET WT.
1	1	CSRT5-161016	CSRT SERIES™ 3 PIPE SLOPE MOUNT 16' FACE X 10' MAST X 16' DEPTH	2551.10	2551.10
2	1	CSRT-RRU3-610	CONSTRUCTOR SERIES 6' X 10' 3 LAYER RRU RACK	215.53	215.53
TOTAL WT. #				2771.26	

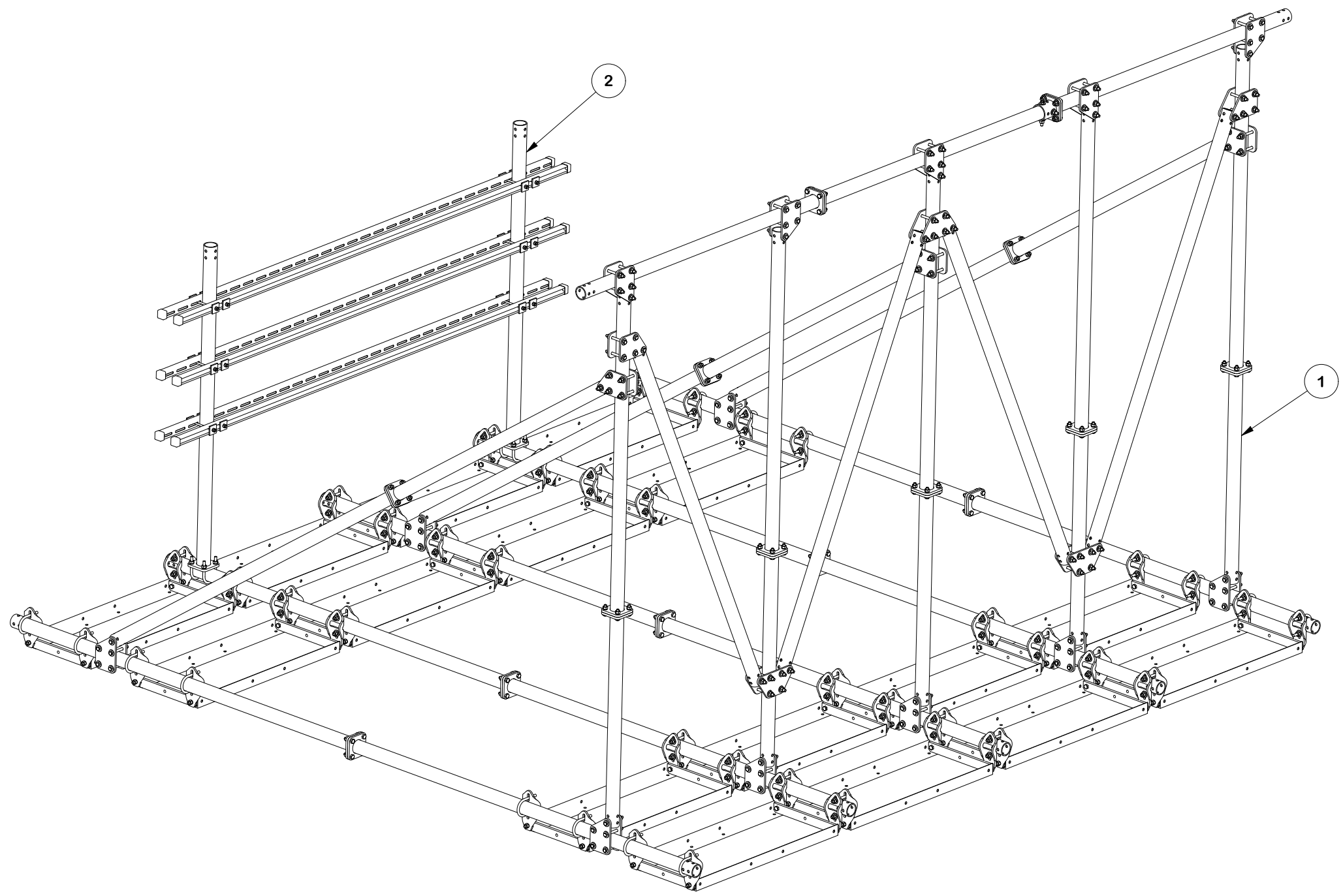

FINISH:
HOT DIP GALVANIZED.

TOLERANCE NOTES

TOLERANCES ON DIMENSIONS, UNLESS OTHERWISE NOTED ARE:
 SAWED, SHEARED AND GAS CUT EDGES ($\pm 0.030"$)
 DRILLED AND GAS CUT HOLES ($\pm 0.030"$) - NO CONING OF HOLES
 LASER CUT EDGES AND HOLES ($\pm 0.010"$) - NO CONING OF HOLES
 BENDS AND ANGLES ARE $\pm 1/2$ DEGREE
 ALL OTHER MACHINING ($\pm 0.030"$)
 ALL OTHER ASSEMBLY ($\pm 0.060"$)

PATENT INFORMATION: WWW.SITEPRO1.COM/PATENTS

PROPRIETARY NOTE:
 THE DATA AND TECHNIQUES CONTAINED IN THIS DRAWING ARE PROPRIETARY INFORMATION OF VALMONT INDUSTRIES AND CONSIDERED A TRADE SECRET. ANY USE OR DISCLOSURE WITHOUT THE CONSENT OF VALMONT INDUSTRIES IS STRICTLY PROHIBITED.

DESCRIPTION
**CSRT SERIES™ 3 PIPE SLOPE MOUNT
 16' FACE X 10' MAST X 16' DEPTH
 W/ RRU RACK**

CPD NO. NCS	DRAWN BY SDR 10/6/2025	ENG. APPROVAL 11/11/2025
CLASS 87	SUB 02	DRAWING USAGE CUSTOMER
CHECKED BY ADB 11/11/2025		



Engineering Support Team:
 sp1engineering@valmont.com

PART NO. CSRT5-161016-R
DWG. NO. CSRT5-161016-R

PARTS LIST									
ITEM	QTY	PART NO.	BOX NO.	PART DESCRIPTION	LENGTH	UNIT WT.	NET WT.		
1	16	X-251012		BALLAST TRAY WELDMENT - SITE PRO 1		36.58	585.29		
2	64	CSRT-PCB	P-CSRT-PCB	CSRT PIPE CLAMP BRACKET KIT		4.25	271.71		
3	18	CSRT-GP30	P-CSRT-GP30	CSRT GUSSET PLATE KIT		10.49	188.73		
4	3	CSRT-GP30D	P-CSRT-GP30D	CSRT DUAL GUSSET PLATE KIT		12.64	37.92		
5	13	X-CSRT-3096FW		CSRT FLANGE PIPE WELDMENT 2-7/8" X 96"		51.47	669.05		
6	11	X-CSRT-3072FW		CSRT FLANGE PIPE WELDMENT 2-7/8" X 72"		39.16	430.71		
7	5	X-CSRT-3048FW		CSRT FLANGE PIPE WELDMENT 2-7/8" X 48"		26.85	134.23		
8	4	X-CSRT-P3096		2-7/8" DIA. PIPE X 96" LONG	96 in	48.99	195.98		
9	1	CSRT-TW1	P-CSRT-TW1	CSRT SINGLE T-WELDMENT KIT		7.84	7.84		
10	48	G12045		1/2" x 4.5" HDG HEX BOLT GR5 FULL THREAD	4 1/2 in	0.30	14.30		
11	60	G1202		1/2" x 2" HDG HEX BOLT GR5	2 in	0.18	10.54		
12	56	G12LW		1/2" HDG LOCKWASHER	1/8 in	0.01	0.78		
13	56	G12NUT		1/2" HDG HEAVY 2H HEX NUT	7/8 in	0.07	4.01		
								TOTAL WT. #	2551.10

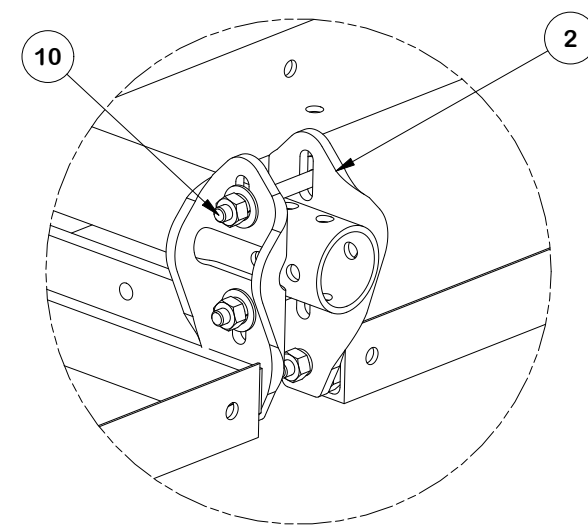
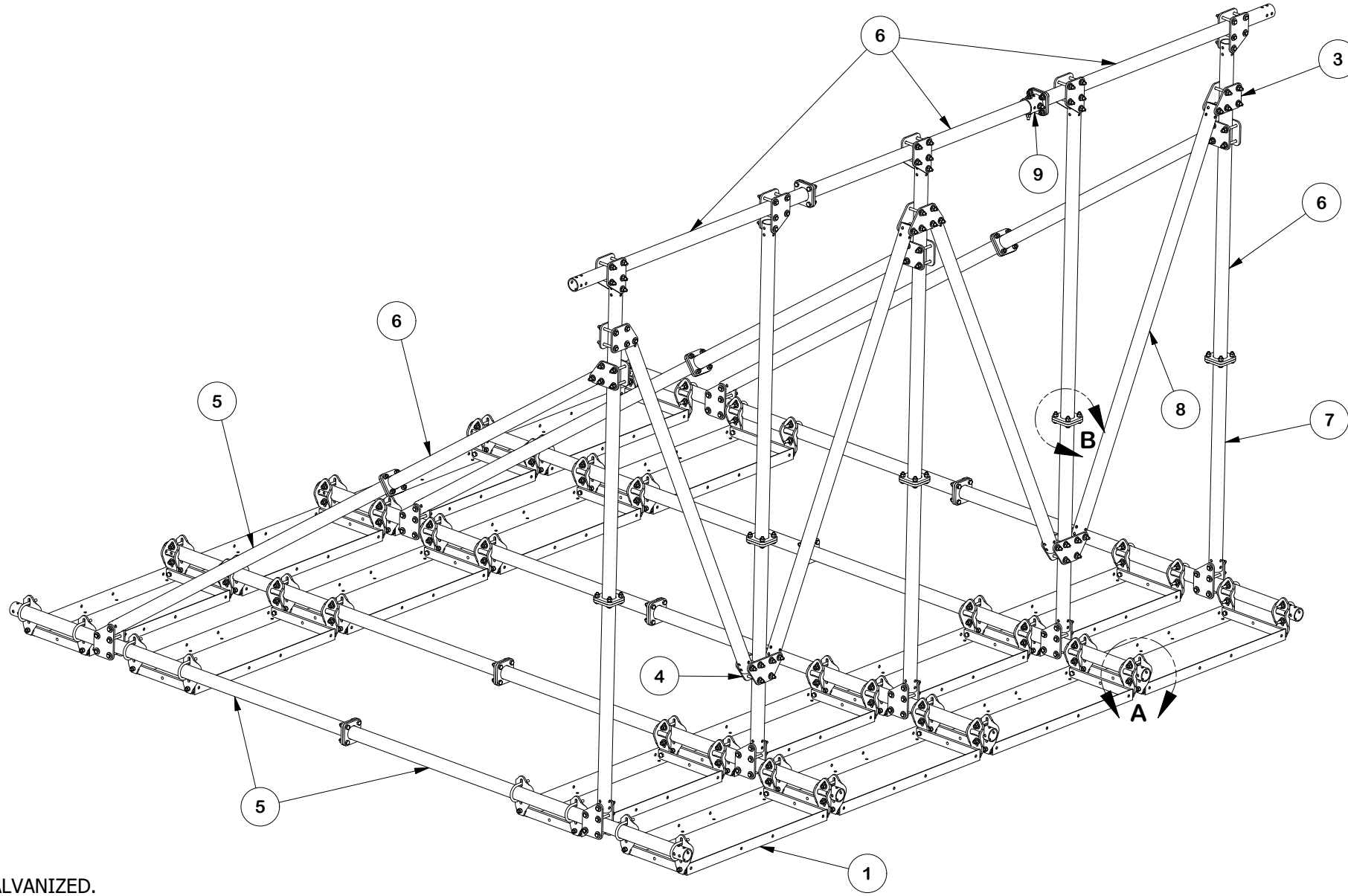

DETAIL A

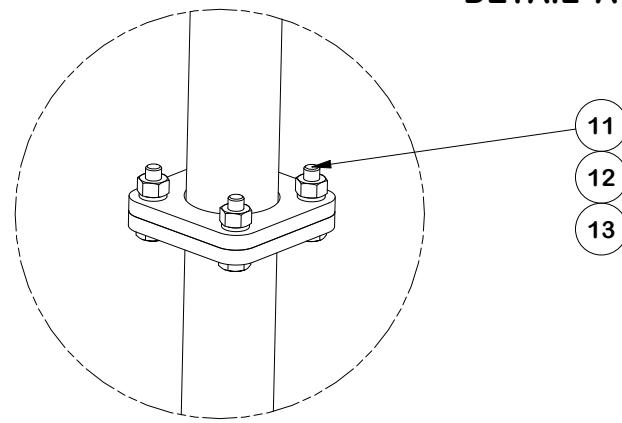

DETAIL B

FINISH:
HOT DIP GALVANIZED.

TOLERANCE NOTES
 TOLERANCES ON DIMENSIONS, UNLESS OTHERWISE NOTED ARE:
 SAWED, SHEARED AND GAS CUT EDGES ($\pm 0.030"$)
 DRILLED AND GAS CUT HOLES ($\pm 0.030"$) - NO CONING OF HOLES
 LASER CUT EDGES AND HOLES ($\pm 0.010"$) - NO CONING OF HOLES
 BENDS AND ANGLES ARE $\pm 1/2$ DEGREE
 ALL OTHER MACHINING ($\pm 0.030"$)
 ALL OTHER ASSEMBLY ($\pm 0.060"$)

PATENT INFORMATION: WWW.SITEPRO1.COM/PATENTS

PROPRIETARY NOTE:
 THE DATA AND TECHNIQUES CONTAINED IN THIS DRAWING ARE PROPRIETARY INFORMATION OF VALMONT INDUSTRIES AND CONSIDERED A TRADE SECRET. ANY USE OR DISCLOSURE WITHOUT THE CONSENT OF VALMONT INDUSTRIES IS STRICTLY PROHIBITED.

DESCRIPTION
CSRT SERIES™ 3 PIPE SLOPE MOUNT
16' FACE X 10' MAST X 16' DEPTH
W/ RRU RACK

CPD NO. **NCS**
 DRAWN BY **SDR 10/6/2025**
 ENG. APPROVAL **11/11/2025**

CLASS **87** SUB **02**
 DRAWING USAGE **CUSTOMER**
 CHECKED BY **ADB 11/11/2025**



A valmont COMPANY

Engineering Support Team:
 sp1engineering@valmont.com

PART NO. **CSRT5-161016**

DWG. NO. **CSRT5-161016-R**

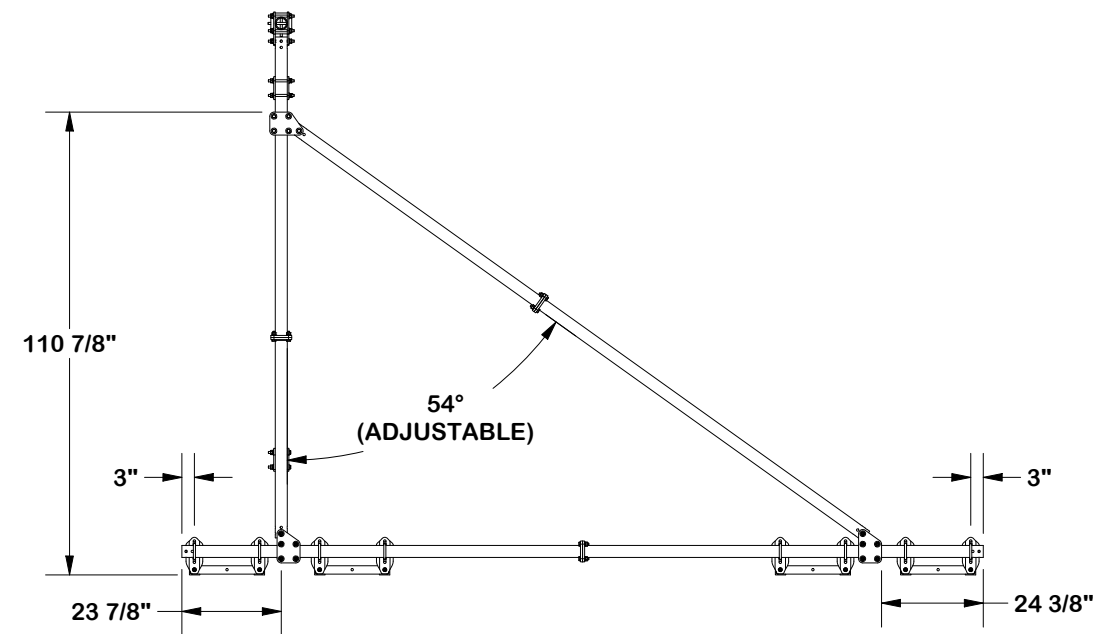
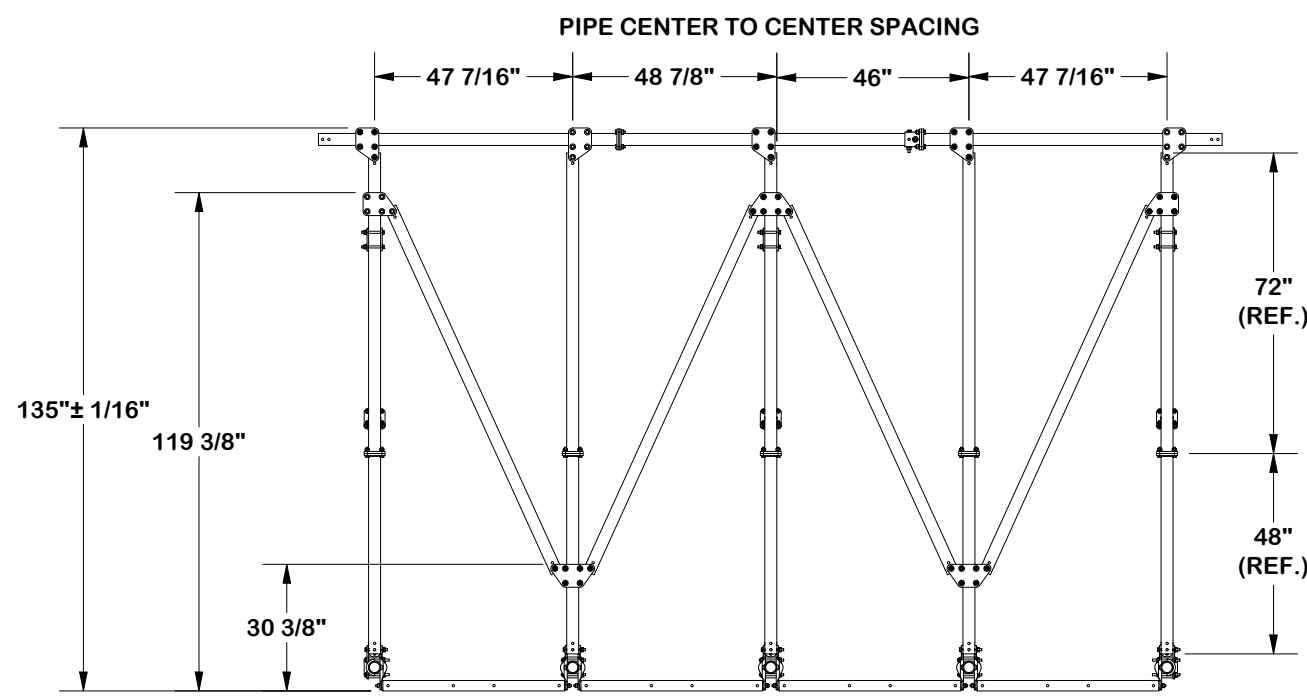
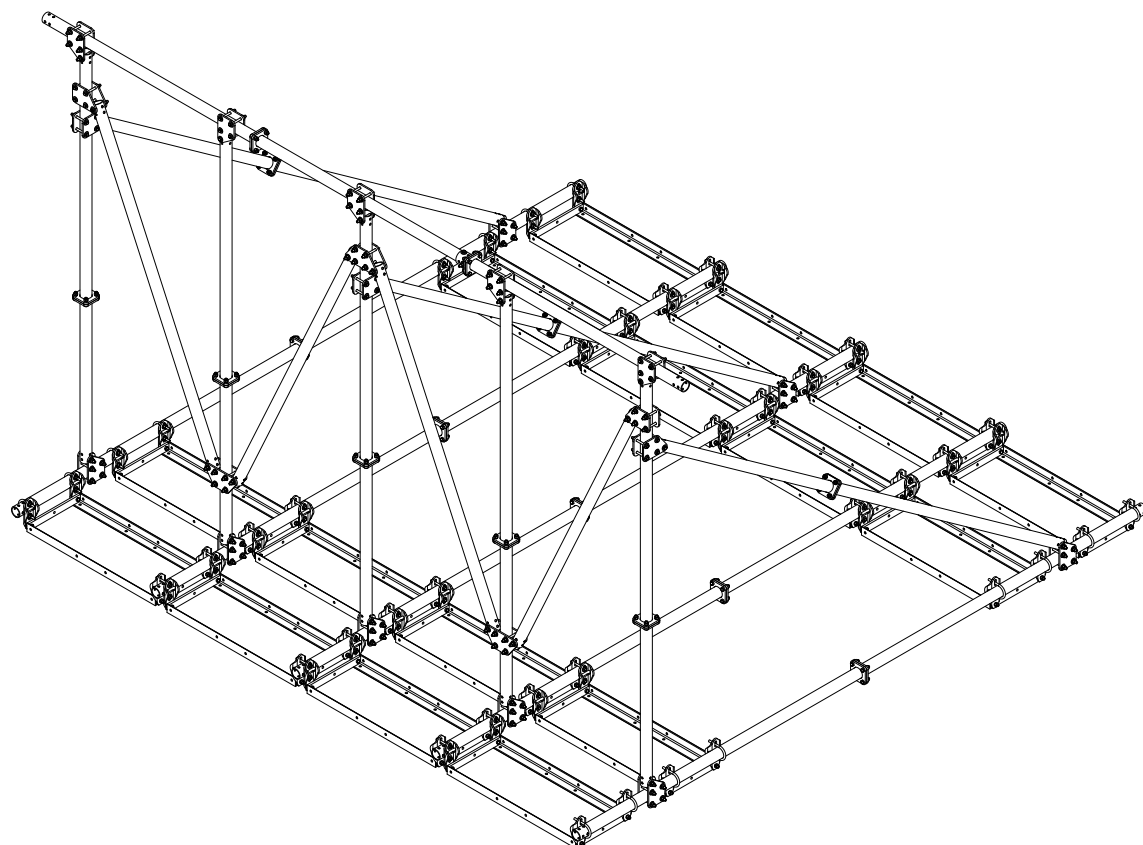
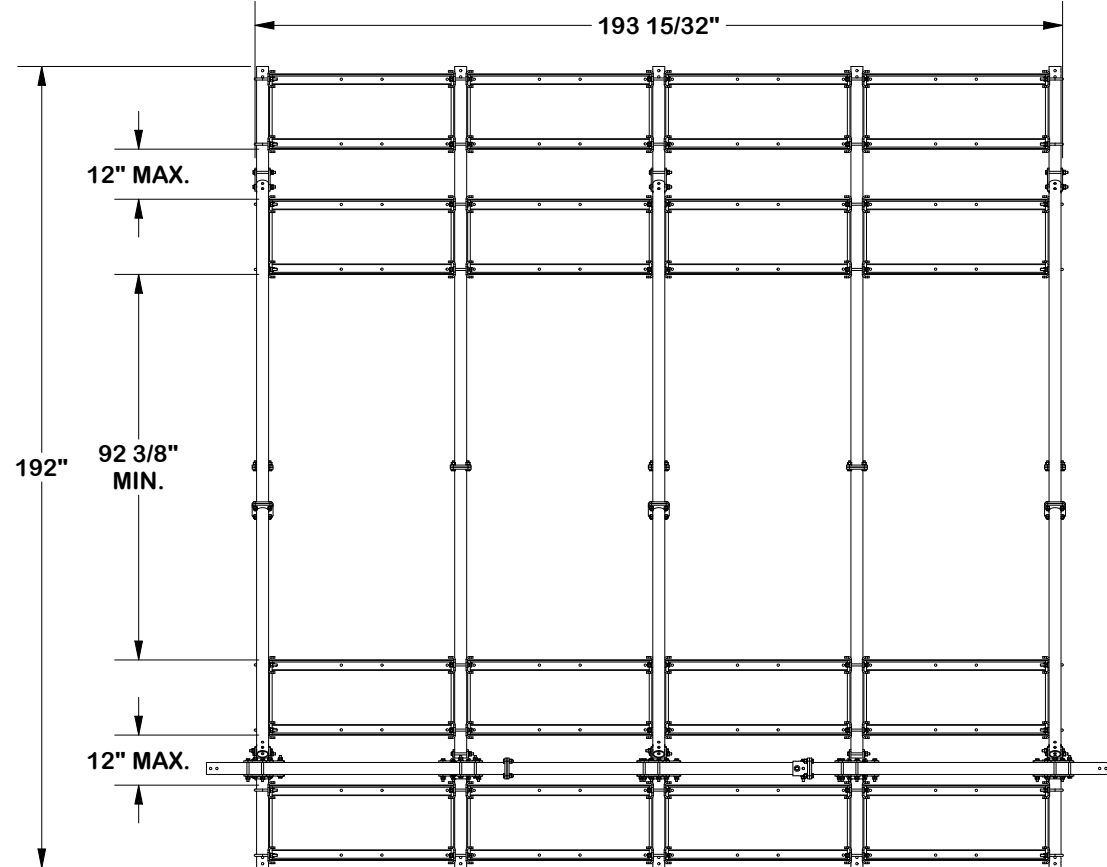

TOLERANCE NOTES

TOLERANCES ON DIMENSIONS, UNLESS OTHERWISE NOTED ARE:
 SAWED, SHEARED AND GAS CUT EDGES ($\pm 0.030"$)
 DRILLED AND GAS CUT HOLES ($\pm 0.030"$) - NO CONING OF HOLES
 LASER CUT EDGES AND HOLES ($\pm 0.010"$) - NO CONING OF HOLES
 BENDS AND ANGLES ARE $\pm 1/2$ DEGREE
 ALL OTHER MACHINING ($\pm 0.030"$)
 ALL OTHER ASSEMBLY ($\pm 0.060"$)

PATENT INFORMATION: WWW.SITEPRO1.COM/PATENTS

PROPRIETARY NOTE:
 THE DATA AND TECHNIQUES CONTAINED IN THIS DRAWING ARE PROPRIETARY INFORMATION OF VALMONT INDUSTRIES AND CONSIDERED A TRADE SECRET. ANY USE OR DISCLOSURE WITHOUT THE CONSENT OF VALMONT INDUSTRIES IS STRICTLY PROHIBITED.

DESCRIPTION
CSRT SERIES™ 3 PIPE SLOPE MOUNT
16' FACE X 10' MAST X 16' DEPTH
W/ RRU RACK

SITE PRO 1
 A valmont COMPANY
 Engineering Support Team:
 sp1engineering@valmont.com

CPD NO. NCS	DRAWN BY SDR 10/6/2025	ENG. APPROVAL 11/11/2025
CLASS 87	SUB 02	DRAWING USAGE CUSTOMER
CHECKED BY ADB 11/11/2025		

PART NO. CSRT5-161016	PAGE 9
DWG. NO. CSRT5-161016-R	

CSRT™ SLOPE REFERENCE

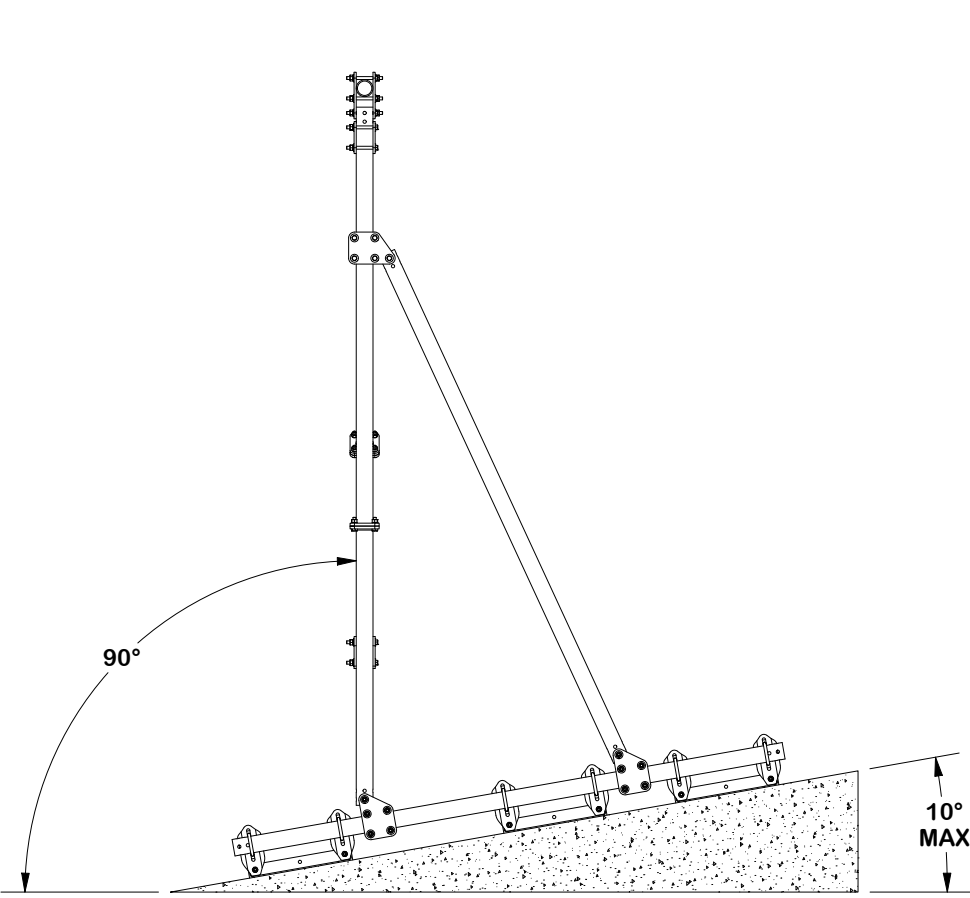

**RIGHT SIDE VIEW
FRONT SLOPE**

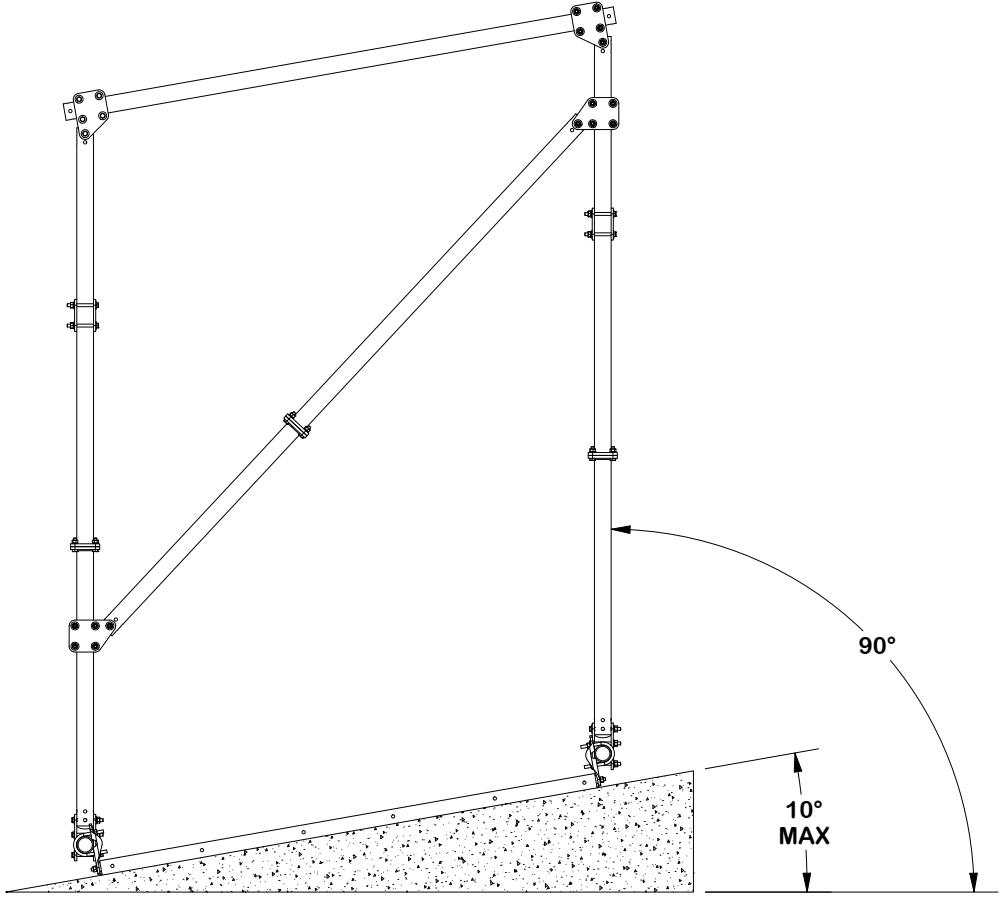

**FRONT VIEW
SIDE SLOPE**

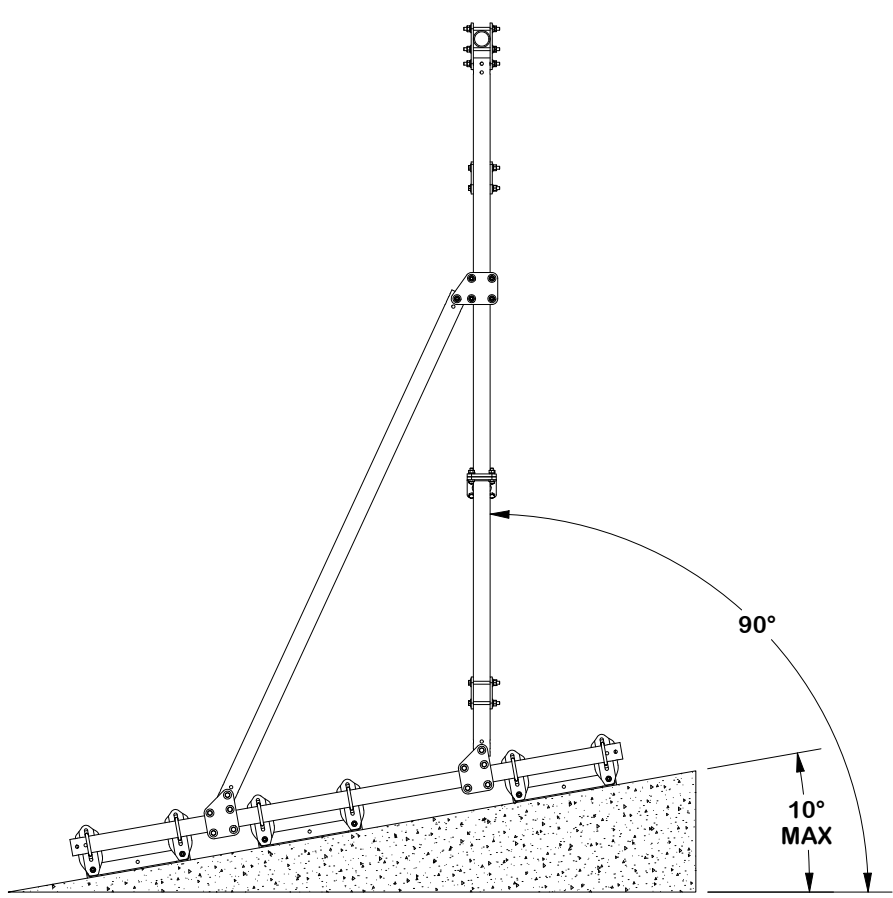

**LEFT SIDE VIEW
BACK SLOPE**

TOLERANCE NOTES

TOLERANCES ON DIMENSIONS, UNLESS OTHERWISE NOTED ARE:
 SAWED, SHEARED AND GAS CUT EDGES ($\pm 0.030"$)
 DRILLED AND GAS CUT HOLES ($\pm 0.030"$) - NO CONING OF HOLES
 LASER CUT EDGES AND HOLES ($\pm 0.010"$) - NO CONING OF HOLES
 BENDS AND ANGLES ARE $\pm 1/2$ DEGREE
 ALL OTHER MACHINING ($\pm 0.030"$)
 ALL OTHER ASSEMBLY ($\pm 0.060"$)

PATENT INFORMATION: WWW.SITEPRO1.COM/PATENTS

PROPRIETARY NOTE:
 THE DATA AND TECHNIQUES CONTAINED IN THIS DRAWING ARE PROPRIETARY INFORMATION OF VALMONT INDUSTRIES AND CONSIDERED A TRADE SECRET. ANY USE OR DISCLOSURE WITHOUT THE CONSENT OF VALMONT INDUSTRIES IS STRICTLY PROHIBITED.

DESCRIPTION
CSRT SERIES™ 3 PIPE SLOPE MOUNT
16' FACE X 10' MAST X 16' DEPTH
W/ RRU RACK

CPD NO. NCS	DRAWN BY SDR 10/6/2025	ENG. APPROVAL 11/11/2025
CLASS 87	SUB 02	DRAWING USAGE CUSTOMER
CHECKED BY ADB 11/11/2025		



Engineering Support Team:
 sp1engineering@valmont.com

A valmont COMPANY

PART NO. CSRT™ SLOPE REF
DWG. NO. CSRT5-161016-R

PARTS LIST						
ITEM	QTY	PART NO.	PART DESCRIPTION	LENGTH	UNIT WT.	NET WT.
1	1	X-CSRT-PCB	PIPE CONNECTION BRACKET	12 in	3.01	3.01
2	1	X-UB1300	1/2" X 3" X 5" X 2" GALV U-BOLT		0.74	0.74
3	1	G1202	1/2" x 2" HDG HEX BOLT GR5	2 in	0.18	0.18
4	2	G12FW	1/2" HDG USS FLATWASHER	3/32 in	0.03	0.07
5	3	G12LW	1/2" HDG LOCKWASHER	1/8 in	0.01	0.04
6	3	G12NUT	1/2" HDG HEAVY 2H HEX NUT	7/8 in	0.07	0.21
					TOTAL WT. #	4.25

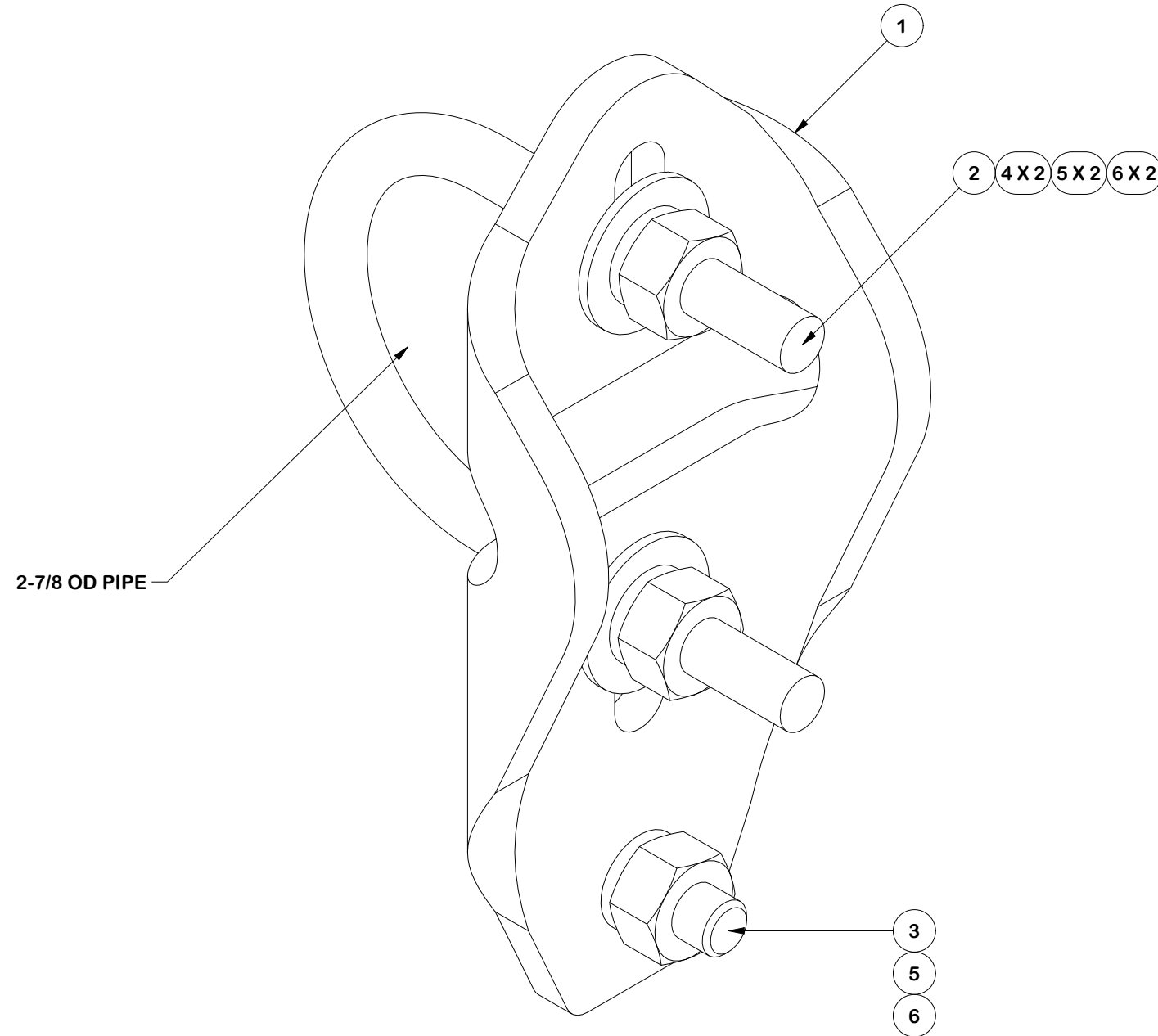

FINISH:
HOT DIP GALVANIZED.

TOLERANCE NOTES

TOLERANCES ON DIMENSIONS, UNLESS OTHERWISE NOTED ARE:
 SAWED, SHEARED AND GAS CUT EDGES ($\pm 0.030"$)
 DRILLED AND GAS CUT HOLES ($\pm 0.030"$) - NO CONING OF HOLES
 LASER CUT EDGES AND HOLES ($\pm 0.010"$) - NO CONING OF HOLES
 BENDS AND ANGLES ARE $\pm 1/2$ DEGREE
 ALL OTHER MACHINING ($\pm 0.030"$)
 ALL OTHER ASSEMBLY ($\pm 0.060"$)

PATENT INFORMATION: WWW.SITEPRO1.COM/PATENTS

PROPRIETARY NOTE:
 THE DATA AND TECHNIQUES CONTAINED IN THIS DRAWING ARE PROPRIETARY INFORMATION OF VALMONT INDUSTRIES AND CONSIDERED A TRADE SECRET. ANY USE OR DISCLOSURE WITHOUT THE CONSENT OF VALMONT INDUSTRIES IS STRICTLY PROHIBITED.

DESCRIPTION
**CSRT SERIES™ 3 PIPE SLOPE MOUNT
 16' FACE X 10' MAST X 16' DEPTH
 W/ RRU RACK**



Engineering Support Team:
 sp1engineering@valmont.com

CPD NO.	DRAWN BY	ENG. APPROVAL
NCS	SDR 10/6/2025	11/11/2025
CLASS	DRAWING USAGE	CHECKED BY
87	CUSTOMER	ADB 11/11/2025

PART NO.	CSRT-PCB
DWG. NO.	CSRT5-161016-R

PARTS LIST						
ITEM	QTY	PART NO.	PART DESCRIPTION	LENGTH	UNIT WT.	NET WT.
1	2	X-CSRT-GP30	3" GUSSET PLATE	12 in	4.04	8.09
2	5	G1205	1/2" x 5" HDG HEX BOLT GR5 FULL THREAD	5 in	0.33	1.63
3	10	G12FW	1/2" HDG USS FLATWASHER	3/32 in	0.03	0.34
4	5	G12LW	1/2" HDG LOCKWASHER	1/8 in	0.01	0.07
5	5	G12NUT	1/2" HDG HEAVY 2H HEX NUT	7/8 in	0.07	0.36
					TOTAL WT. #	10.49

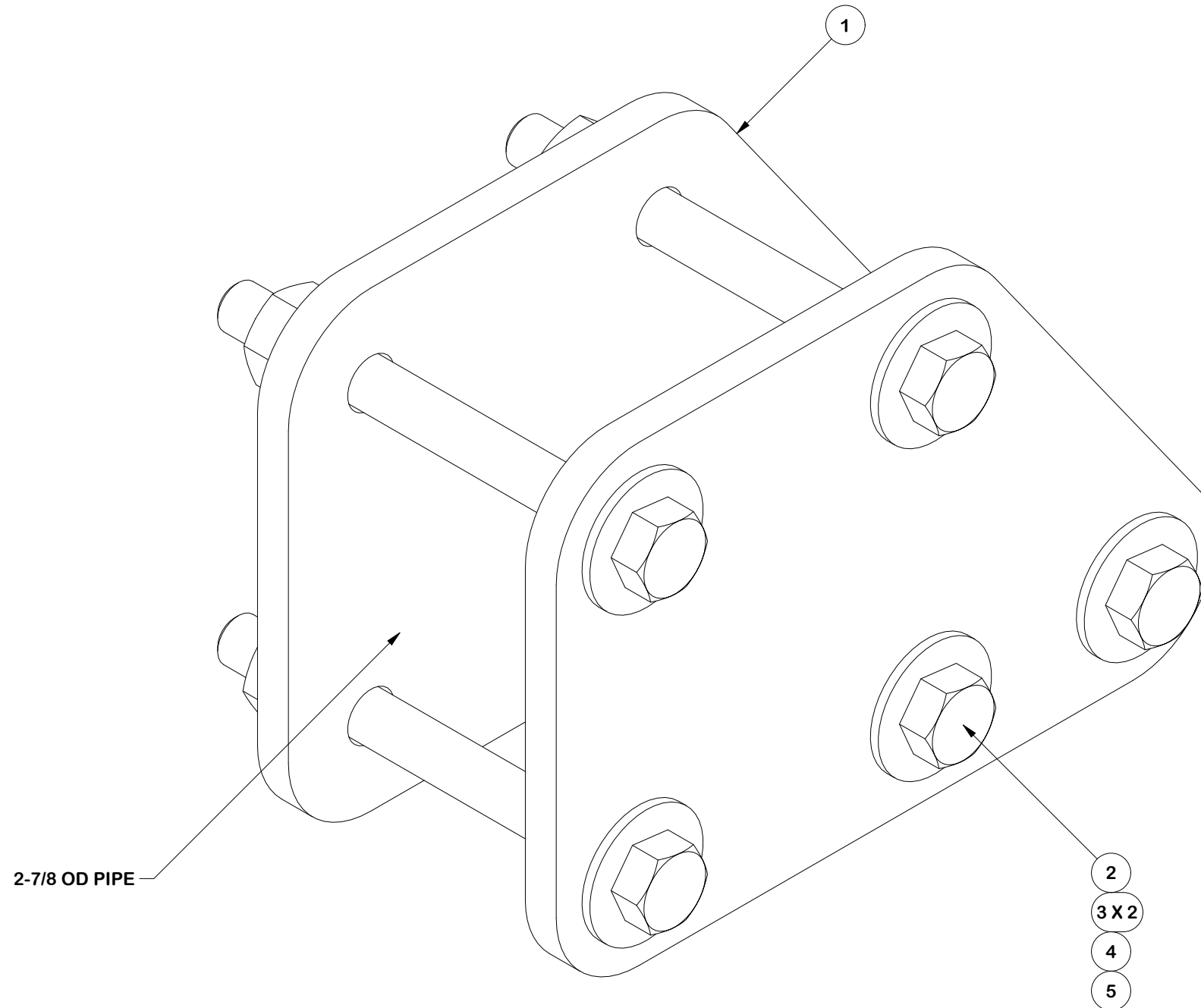

FINISH:
HOT DIP GALVANIZED.

TOLERANCE NOTES

TOLERANCES ON DIMENSIONS, UNLESS OTHERWISE NOTED ARE:
 SAWED, SHEARED AND GAS CUT EDGES ($\pm 0.030"$)
 DRILLED AND GAS CUT HOLES ($\pm 0.030"$) - NO CONING OF HOLES
 LASER CUT EDGES AND HOLES ($\pm 0.010"$) - NO CONING OF HOLES
 BENDS AND ANGLES ARE $\pm 1/2$ DEGREE
 ALL OTHER MACHINING ($\pm 0.030"$)
 ALL OTHER ASSEMBLY ($\pm 0.060"$)

PATENT INFORMATION: WWW.SITEPRO1.COM/PATENTS

PROPRIETARY NOTE:
 THE DATA AND TECHNIQUES CONTAINED IN THIS DRAWING ARE PROPRIETARY INFORMATION OF VALMONT INDUSTRIES AND CONSIDERED A TRADE SECRET. ANY USE OR DISCLOSURE WITHOUT THE CONSENT OF VALMONT INDUSTRIES IS STRICTLY PROHIBITED.

DESCRIPTION
**CSRT SERIES™ 3 PIPE SLOPE MOUNT
 16' FACE X 10' MAST X 16' DEPTH
 W/ RRU RACK**

CPD NO. NCS	DRAWN BY SDR 10/6/2025	ENG. APPROVAL 11/11/2025
CLASS 87	SUB 02	DRAWING USAGE CUSTOMER
CHECKED BY ADB 11/11/2025		



Engineering
 Support Team:
 sp1engineering@valmont.com

PART NO. CSRT-GP30
DWG. NO. CSRT5-161016-R

PARTS LIST						
ITEM	QTY	PART NO.	PART DESCRIPTION	LENGTH	UNIT WT.	NET WT.
1	2	X-CSRT-GP30D	3" DOUBLE GUSSET PLATE	24 in	4.88	9.76
2	6	G1205	1/2" x 5" HDG HEX BOLT GR5 FULL THREAD	5 in	0.33	1.96
3	12	G12FW	1/2" HDG USS FLATWASHER	3/32 in	0.03	0.41
4	6	G12LW	1/2" HDG LOCKWASHER	1/8 in	0.01	0.08
5	6	G12NUT	1/2" HDG HEAVY 2H HEX NUT	7/8 in	0.07	0.43
					TOTAL WT. #	12.64

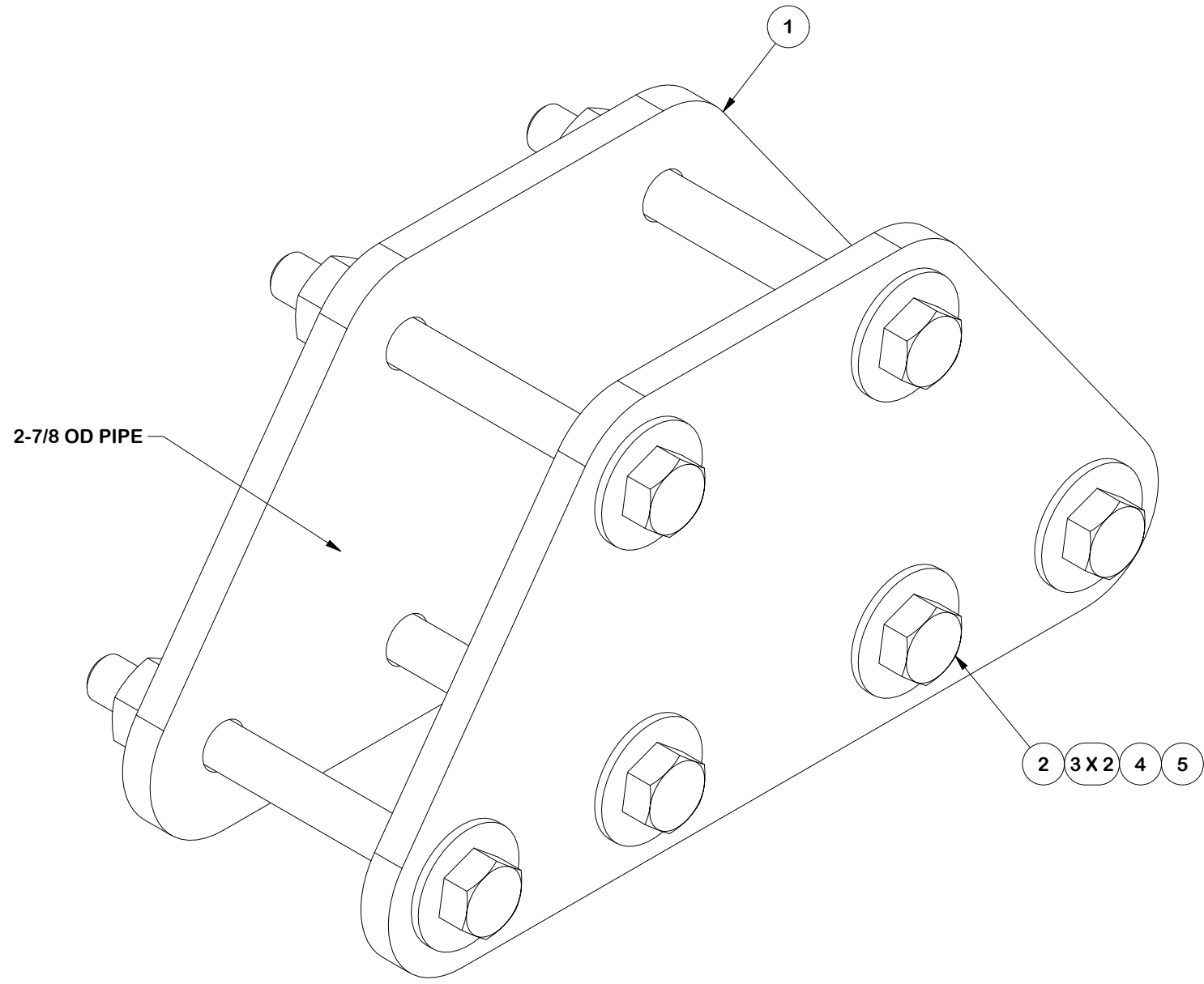

FINISH:
HOT DIP GALVANIZED.

TOLERANCE NOTES

TOLERANCES ON DIMENSIONS, UNLESS OTHERWISE NOTED ARE:
 SAWED, SHEARED AND GAS CUT EDGES ($\pm 0.030"$)
 DRILLED AND GAS CUT HOLES ($\pm 0.030"$) - NO CONING OF HOLES
 LASER CUT EDGES AND HOLES ($\pm 0.010"$) - NO CONING OF HOLES
 BENDS AND ANGLES ARE $\pm 1/2$ DEGREE
 ALL OTHER MACHINING ($\pm 0.030"$)
 ALL OTHER ASSEMBLY ($\pm 0.060"$)

PATENT INFORMATION: WWW.SITEPRO1.COM/PATENTS

PROPRIETARY NOTE:
 THE DATA AND TECHNIQUES CONTAINED IN THIS DRAWING ARE PROPRIETARY INFORMATION OF VALMONT INDUSTRIES AND CONSIDERED A TRADE SECRET. ANY USE OR DISCLOSURE WITHOUT THE CONSENT OF VALMONT INDUSTRIES IS STRICTLY PROHIBITED.

DESCRIPTION
**CSRT SERIES™ 3 PIPE SLOPE MOUNT
 16' FACE X 10' MAST X 16' DEPTH
 W/ RRU RACK**

CPD NO. NCS	DRAWN BY SDR 10/6/2025	ENG. APPROVAL 11/11/2025
CLASS 87	SUB 02	DRAWING USAGE CUSTOMER
CHECKED BY ADB 11/11/2025		



Engineering Support Team:
 sp1engineering@valmont.com

PART NO. CSRT-GP30D
DWG. NO. CSRT5-161016-R

PARTS LIST						
ITEM	QTY	PART NO.	PART DESCRIPTION	LENGTH	UNIT WT.	NET WT.
1	1	X-CSRT-TW	3-1/2" T-WELDMENT		4.93	4.93
2	2	X-UB1300	1/2" X 3" X 5" X 2" GALV U-BOLT		0.74	1.48
3	2	G1205	1/2" x 5" HDG HEX BOLT GR5 FULL THREAD	5 in	0.33	0.65
4	8	G12FW	1/2" HDG USS FLATWASHER	3/32 in	0.03	0.27
5	6	G12LW	1/2" HDG LOCKWASHER	1/8 in	0.01	0.08
6	6	G12NUT	1/2" HDG HEAVY 2H HEX NUT	7/8 in	0.07	0.43
					TOTAL WT. #	7.84

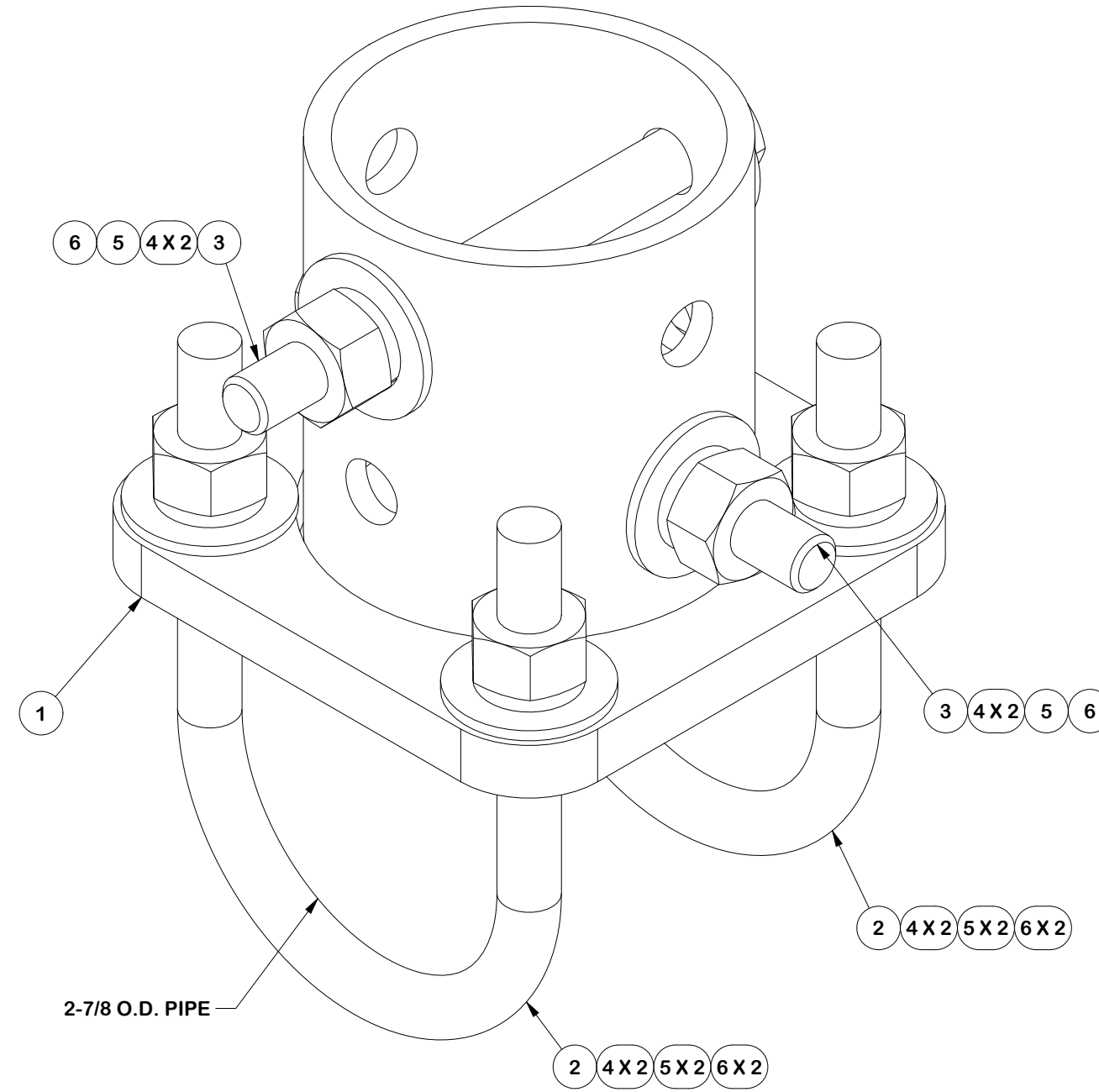

FINISH:
HOT DIP GALVANIZED.

TOLERANCE NOTES
 TOLERANCES ON DIMENSIONS, UNLESS OTHERWISE NOTED ARE:
 SAWED, SHEARED AND GAS CUT EDGES ($\pm 0.030"$)
 DRILLED AND GAS CUT HOLES ($\pm 0.030"$) - NO CONING OF HOLES
 LASER CUT EDGES AND HOLES ($\pm 0.010"$) - NO CONING OF HOLES
 BENDS AND ANGLES ARE $\pm 1/2$ DEGREE
 ALL OTHER MACHINING ($\pm 0.030"$)
 ALL OTHER ASSEMBLY ($\pm 0.060"$)

PATENT INFORMATION: WWW.SITEPRO1.COM/PATENTS

PROPRIETARY NOTE:
 THE DATA AND TECHNIQUES CONTAINED IN THIS DRAWING ARE PROPRIETARY INFORMATION OF VALMONT INDUSTRIES AND CONSIDERED A TRADE SECRET. ANY USE OR DISCLOSURE WITHOUT THE CONSENT OF VALMONT INDUSTRIES IS STRICTLY PROHIBITED.

DESCRIPTION
**CSRT SERIES™ 3 PIPE SLOPE MOUNT
 16' FACE X 10' MAST X 16' DEPTH
 W/ RRU RACK**

CPD NO. NCS	DRAWN BY SDR 10/6/2025	ENG. APPROVAL 11/11/2025
CLASS 87	SUB 02	DRAWING USAGE CUSTOMER
CHECKED BY ADB 11/11/2025		

SITE PRO 1
 A valmont COMPANY

Engineering Support Team:
 sp1engineering@valmont.com

PART NO. CSRT-TW1
DWG. NO. CSRT5-161016-R

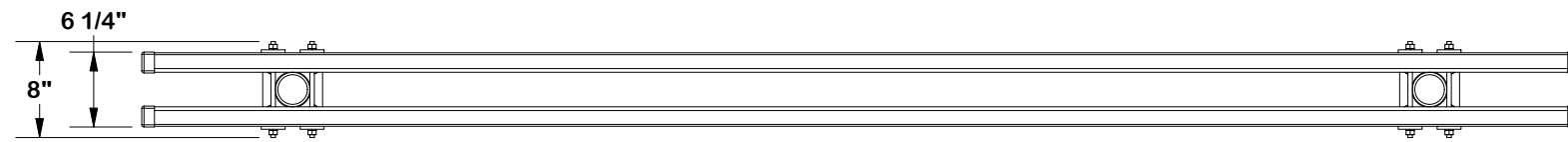

PARTS LIST						
ITEM	QTY	PART NO.	PART DESCRIPTION	LENGTH	UNIT WT.	NET WT.
1	2	X-CSRT-3072FW	CSRT FLANGE PIPE WELDMENT 2-7/8" X 72"		39.16	78.31
2	6	UNT10	UNISTRUT	120 in	20.38	122.27
3	12	UNICAP	UNISTRUT END CAP		0.03	0.39
4	4	X-UB1300	1/2 X 3" X 5" X 2" U-BOLT	5 in	0.74	2.95
5	8	G12LW	1/2" HDG LOCKWASHER	1/8 in	0.01	0.11
6	8	G12NUT	1/2" HDG HEAVY 2H HEX NUT	7/8 in	0.07	0.57
7	12	G38R-8	3/8" X 8" THREADED ROD (HDG.)		0.25	3.01
8	24	SQW38	3/8" SQUARE WASHER	2 in	0.29	6.94
9	24	G38LW	3/8" HDG LOCKWASHER		0.01	0.16
10	24	G38NUT	3/8" HDG HEAVY 2H HEX NUT		0.03	0.81
TOTAL WT. #						219.98

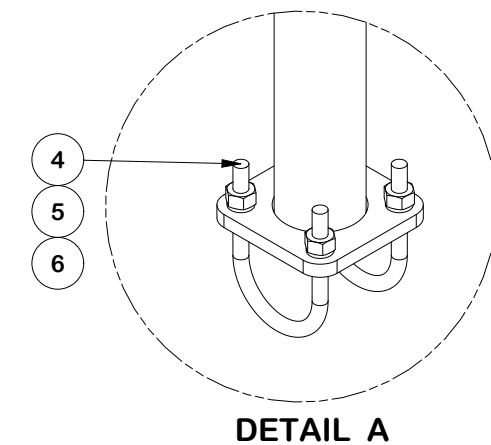
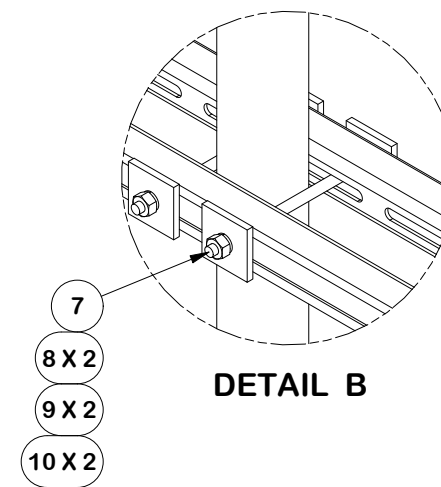
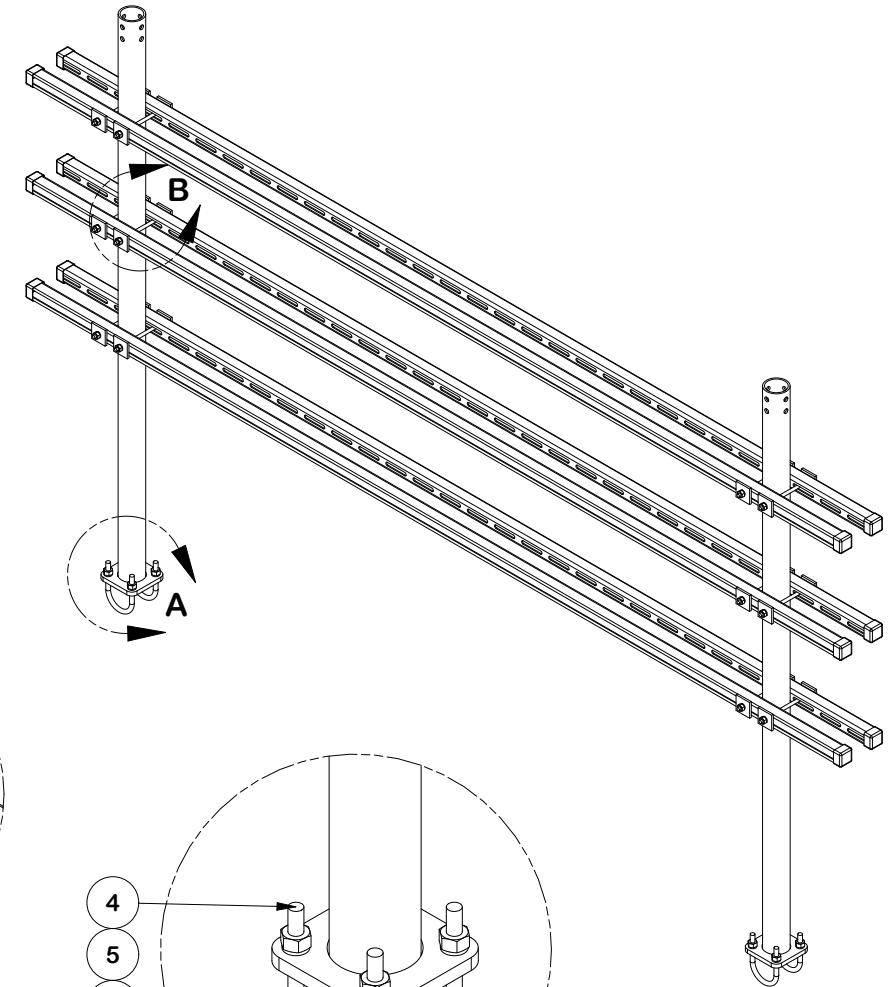
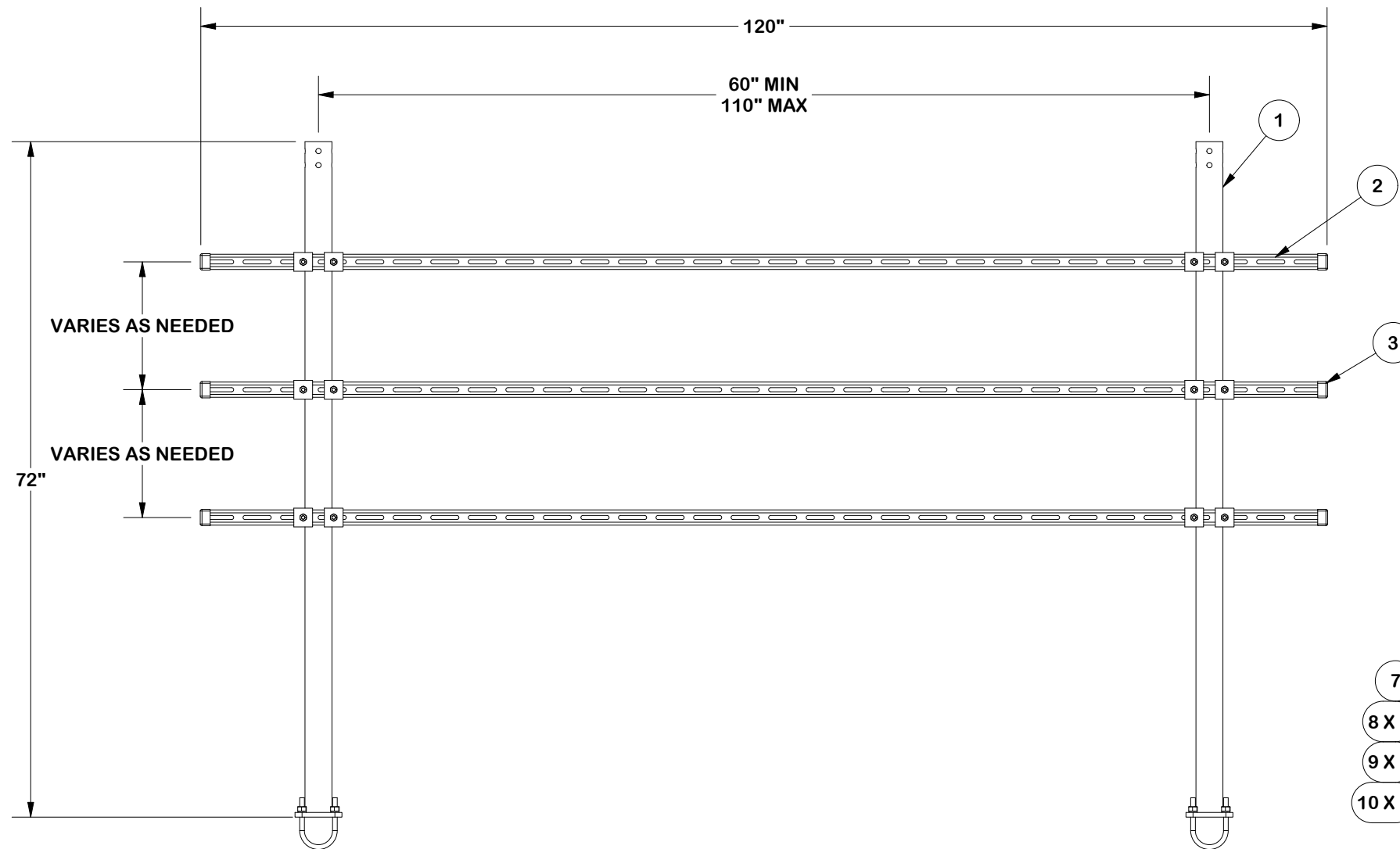

FINISH:
HOT DIP GALVANIZED.

TOLERANCE NOTES

TOLERANCES ON DIMENSIONS, UNLESS OTHERWISE NOTED ARE:
 SAWED, SHEARED AND GAS CUT EDGES ($\pm 0.030"$)
 DRILLED AND GAS CUT HOLES ($\pm 0.030"$) - NO CONING OF HOLES
 LASER CUT EDGES AND HOLES ($\pm 0.010"$) - NO CONING OF HOLES
 BENDS AND ANGLES ARE $\pm 1/2$ DEGREE
 ALL OTHER MACHINING ($\pm 0.030"$)
 ALL OTHER ASSEMBLY ($\pm 0.060"$)

PATENT INFORMATION: WWW.SITEPRO1.COM/PATENTS

PROPRIETARY NOTE:
 THE DATA AND TECHNIQUES CONTAINED IN THIS DRAWING ARE PROPRIETARY INFORMATION OF VALMONT INDUSTRIES AND CONSIDERED A TRADE SECRET. ANY USE OR DISCLOSURE WITHOUT THE CONSENT OF VALMONT INDUSTRIES IS STRICTLY PROHIBITED.

DESCRIPTION
CSRT SERIES™ 3 PIPE SLOPE MOUNT
16' FACE X 10' MAST X 16' DEPTH
W/ RRU RACK

CPD NO.	DRAWN BY	ENG. APPROVAL
NCS	SDR 10/6/2025	11/11/2025
CLASS	DRAWING USAGE	CHECKED BY
87	CUSTOMER	ADB 11/11/2025



Engineering Support Team:
 sp1engineering@valmont.com

PART NO.	CSRT-RRU3-610
DWG. NO.	CSRT5-161016-R